

## PRODUCT PRESERVERS® ANTI-SCALE SYSTEM

**THE PRODUCT PRESERVERS® ANTI-SCALE SYSTEM IS DESIGNED TO PROTECT YOUR TANKLESS WATER HEATER FROM THE DAMAGING EFFECTS OF HARD WATER SCALE**

### WHAT IS HARD WATER SCALE:

- More than 85% of American homes have hard water with high mineral content (generally magnesium and calcium)
- These minerals can precipitate out of the water leaving behind a solid mineral deposit called hard water scale.
- Scale acts as a thermal insulator preventing full transfer of heat from the burner into the water reducing the efficiency of the water heater.
- Hard water scale can lead to overheating and eventually damage to the water heater components.

### HOW IT WORKS:

- As water flows through the filter, minerals form into inactive scale crystals.
- This inactive form of scale flows through the tankless water heater without sticking to any components.
- This system can even reduce scale formation on other hot water appliances and fixtures.

### BENEFITS:

- Provides active protection against scale formation so there is no requirement to flush/descale the tankless water heater.
- Does not add chemicals to the water or require electricity.
- Virtually maintenance free; one simple filter change every two years to ensure continuous protection from the effects of hard water scale.

### WARRANTY:

- The Product Preservers® cartridge system is warranted to be free of defects in materials and workmanship for two years from the date of original shipment.
- Product Preservers® filter cartridges are warranted for performance for a period of two years from the date of original installation when installed and operated in accordance with the instructions in the corresponding Installation and Operation Manual.



**MODEL: PP-AS20**



# COMMERCIAL-GRADE RESIDENTIAL GAS PRODUCT PRESERVERS

Model	Connection Size	Operating Pressure Range	Replacement Cycle	Operating Temperature	Rated Flow	Weight
PP-AS20	3/4" NPT	20-100 psi	2 years	40-90° F	7 gpm	5.6 lbs

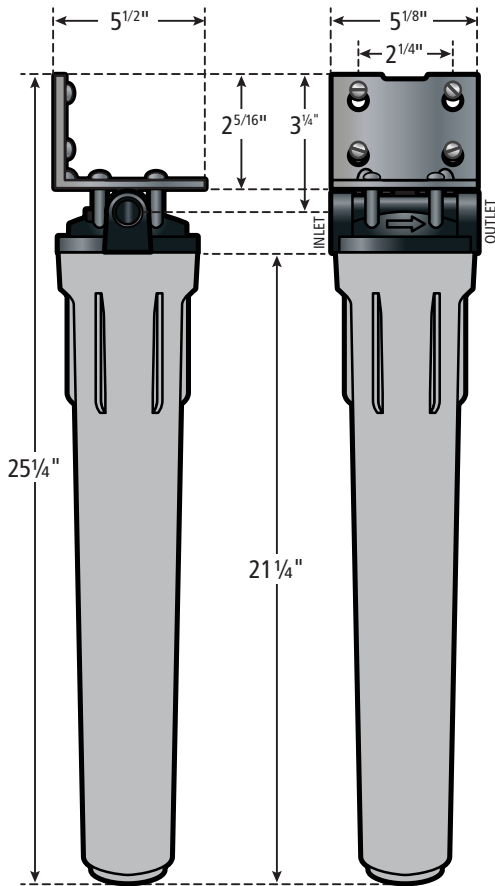

### REPLACEMENT FILTER CARTRIDGE:

Part Number: PP-AS20R  
Replacement Cycle: 2 years

### WATER QUALITY GUIDELINES:

Hardness: <25 grains  
Chlorine: <2 ppm

### OPERATING RECOMMENDATIONS:

- Please read installation instructions carefully and completely before installing unit.
- Install on cold water lines only.
- Install unit in a vertical, upright, and level position.
- Allow a minimum of 3" under the system for filter cartridge replacements.

## SPECIFICATION

Product Preservers® Anti-Scale System shall be installed on the cold water line upstream of the tankless water heater. A Product Preservers® system may also be used to protect multiple appliances as long as the combined peak flow rate for all appliances is less than the rated flow of the Product Preservers® system. The system shall be plumbed with a bypass line to allow continued appliance operation during filter service or replacement. The Product Preservers® system should be installed in an area with sufficient clearance for filter replacements and should be installed per the installation manual provided with each system.

For technical information call (800) 999-9515. American Water Heaters reserves the right to make product changes or improvements without prior notice.